

GALVANIZED STEEL BUCKET - MODEL: BKT-GAL-500

APPROX WEIGHT: 8.74 lbs.
 DOES NOT INCLUDE WEIGHT OF POWER OR PACKAGING!!!

*** ANY ADDITIONS, DELETIONS, OR OMISSIONS MUST BE CORRECTED ON THIS DRAWING AS THIS DRAWING WILL BE CONSIDERED ALL INCLUSIVE ***
 ALL GRAPHICS PROVIDED ARE FOR REFERENCE ONLY. IF CERTAIN DIMENSIONS ARE CRITICAL PLEASE VERIFY THOSE DIMENSIONS WITH YOUR SALESPERSON

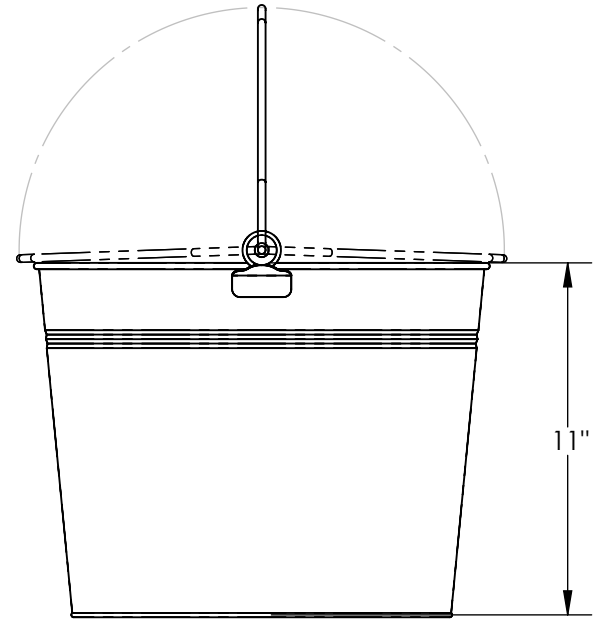
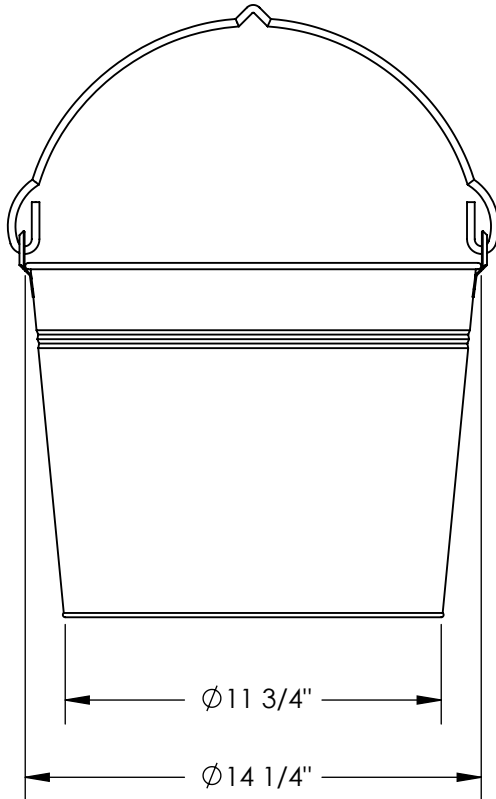

STANDARD FEATURES

- MODEL NUMBER IS: BKT-GAL-500
- OVERALL SMALL DIAMETER IS: 11 3/4"
- OVERALL LARGE DIAMETER IS: 14 1/4"
- OVERALL HEIGHT IS: 11"
- MAX VOLUME IS: 6 GALLONS OR 22.7 LITERS

SPECIAL FEATURES

NONE

| | | |
|----------|---|--|
| APPROVAL | I, THE UNDERSIGNED, AGREE THAT THE PRODUCT AS REPRESENTED SATISFIES DESIGN AND DIMENSION REQUIREMENTS. I ALSO ACKNOWLEDGE MY DUTY TO CONFIRM PRODUCT AND INSTALLATION COMPLIANCE WITH ALL APPLICABLE FEDERAL, STATE AND LOCAL REGULATIONS AND STANDARDS. ALL SPECIAL UNITS ARE NON-RETURNABLE <input type="checkbox"/> As drawn <input type="checkbox"/> As marked | |
| | Signed: _____ Date: _____ LEAD TIME WILL START UPON RECEIPT OF SIGNED APPROVAL DRAWING | |

| | | |
|----------------------|------------|------------|
| DISTRIBUTOR'S NAME: | | P.O.# |
| VESTIL MANUFACTURING | | X |
| DRAWN BY: | DATE: | W.O.# |
| J. RIDLEY | 02/11/09 | X |
| REFERENCE: | SCALE: 1:6 | SALES: |
| X | X | X |
| | QUOTE # | FILE NAME: |
| | X | 30-007-876 |